

TAPE DIMENSIONS

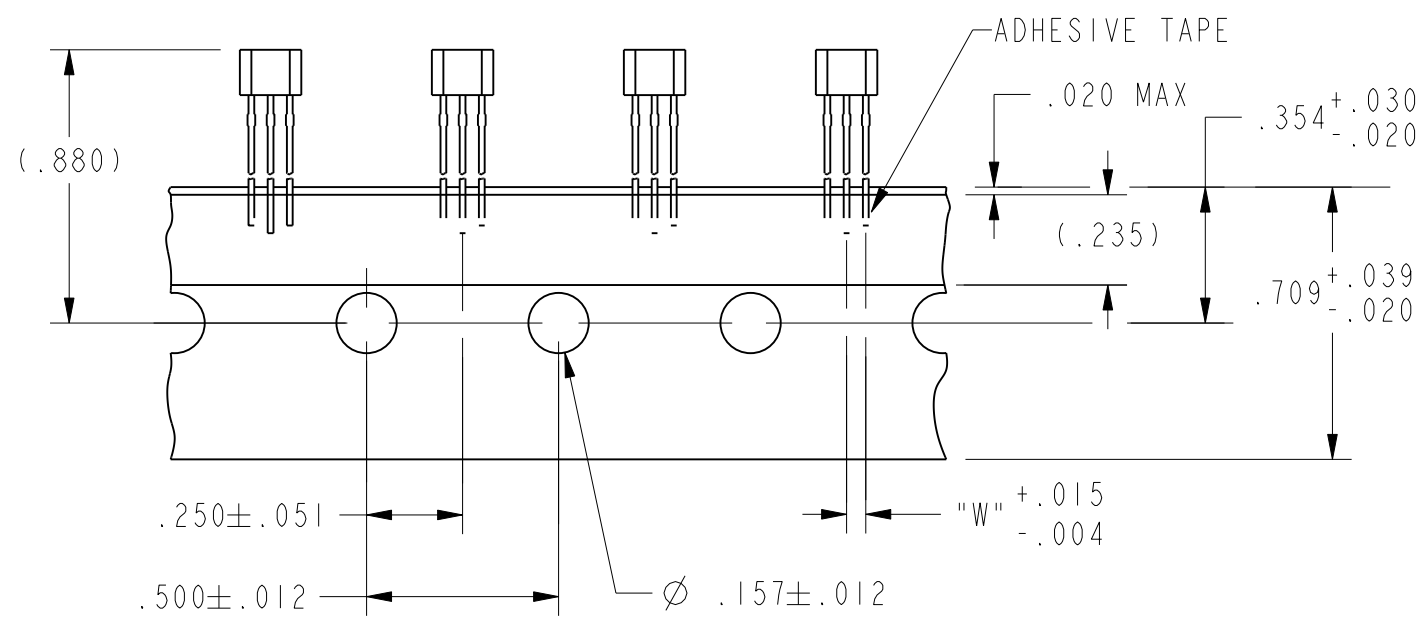

TAPE DIMENSIONS

TAPE PACKING OPTIONS

TAPE STYLE

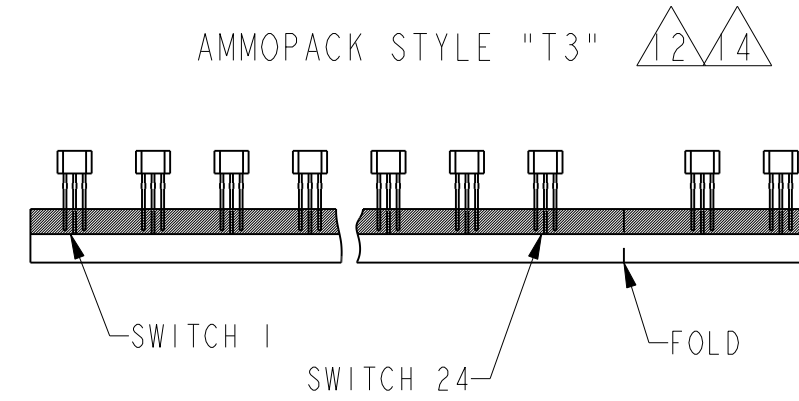
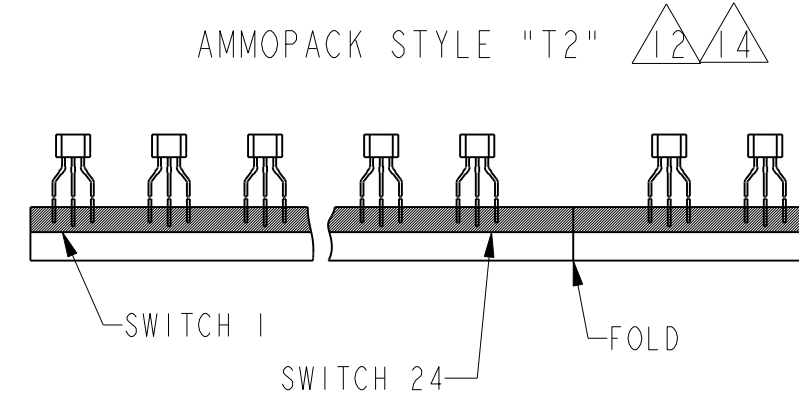

NOTES

- 1 CENTERLINE OF HALL CELL
- 2 THE + MAGNETIC FLUX IS IN THE DIRECTION SHOWN (THIS ASSUMES THE CONVENTION THAT THE DIRECTION OF THE EXTERNAL FLUX OF A MAGNET IS FROM THE NORTH TO THE SOUTH POLE OF THE MAGNET)
- 3 - THE DEVICE CANNOT BE DAMAGED BY MAGNETIC OVERDRIVE
- 4 - OUTPUT TYPE - RATIO METRIC
- 5 - LEADS MUST BE ADEQUATELY SUPPORTED DURING ANY FORMING/SHEERING OPERATION TO ASSURE THAT THE LEADS ARE NOT STRESSED WITHIN THE PLASTIC
- 6 - PCB WAVE SOLDERING GUIDELINES ARE AS FOLLOWS:
250°C TO 260°C SOLDERING TEMPERATURE 3 SECONDS MAX SOLDERING TIME
LEAD REFERENCE DIMENSIONS DO NOT INCLUDE SOLDER THICKNESS
- 7 BURRS ARE ALLOWED ONLY IF FULL LENGTH OF LEADS WILL PASS THROUGH Ø .023 HOLE. LEAD REFERENCE DIMENSIONS DO NOT INCLUDE SOLDER THICKNESS
- 8 DIMENSION REFERS TO THE LOCATION OF LEAD CENTERLINES AS THE EXIT THE PLASTIC PACKAGE
- 9 - SOME COMBINATIONS OF BASIC LISTING AND PACKAGE OPTIONS MAY NOT BE AVAILABLE
- 10 ABSOLUTE MAXIMUM RATINGS ARE THE EXTREME LIMITS THE DEVICE WILL MOMENTARILY WITHSTAND WITHOUT DAMAGE TO THE DEVICE. ELECTRICAL AND MAGNETIC CHARACTERISTICS ARE NOT GUARANTEED IF THE RATED VOLTAGE AND/OR CURRENTS ARE EXCEEDED NOR WILL THE DEVICE NECESSARILY OPERATE AT ABSOLUTE MAXIMUM RATINGS
- 11 LEAD STRAIGHTNESS MAY BE DETERIORATED ON SOME UNITS BY BULK PACKAGING. APPLICATIONS HAVING A CRITICAL LEAD STRAIGHTNESS REQUIREMENT SHOULD USE A TAPE PACKAGING OPTION
- 12 AMMOPACK STYLE "T2" & "T3". 24 SWITCHES BETWEEN FOLDS, SKIP 1 SPACE AT FOLD. MAY BE REFERRED TO AS "FAN FOLD"
- 13 MOLDED PART DIMENSIONS DO NOT INCLUDE FLASH. FLASH IS LIMITED TO .005 MAX
- 14 TAPE AND AMMOPACK PER EIA-468

CATALOG LISTING	TAPE STYLE	DIM "L"	DIM "W"	COMMENTS
SS49E	NONE	.590	.050	BULK - 1000/BAG
SS49E-T2	T2	.590	.100	5000/BOX
SS49E-T3	T3	.590	.050	5000/BOX
SS49E-L	NONE	.735	.050	BULK - 1000/BAG
SS49E-F	NONE	.590	.100	BULK - 1000/BAG

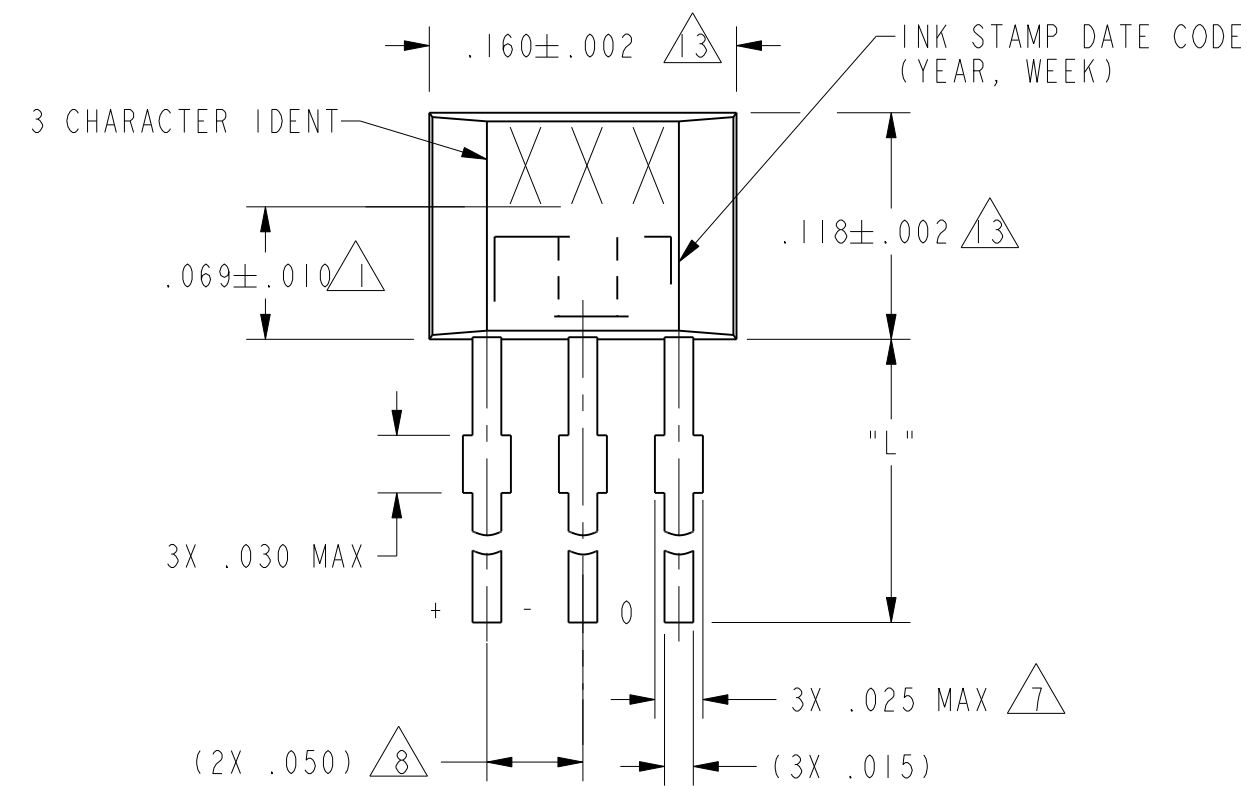
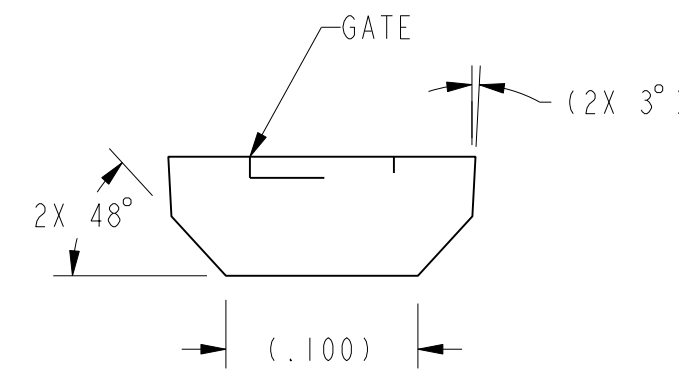

LEAD STYLES "STD", "T2", "T3"

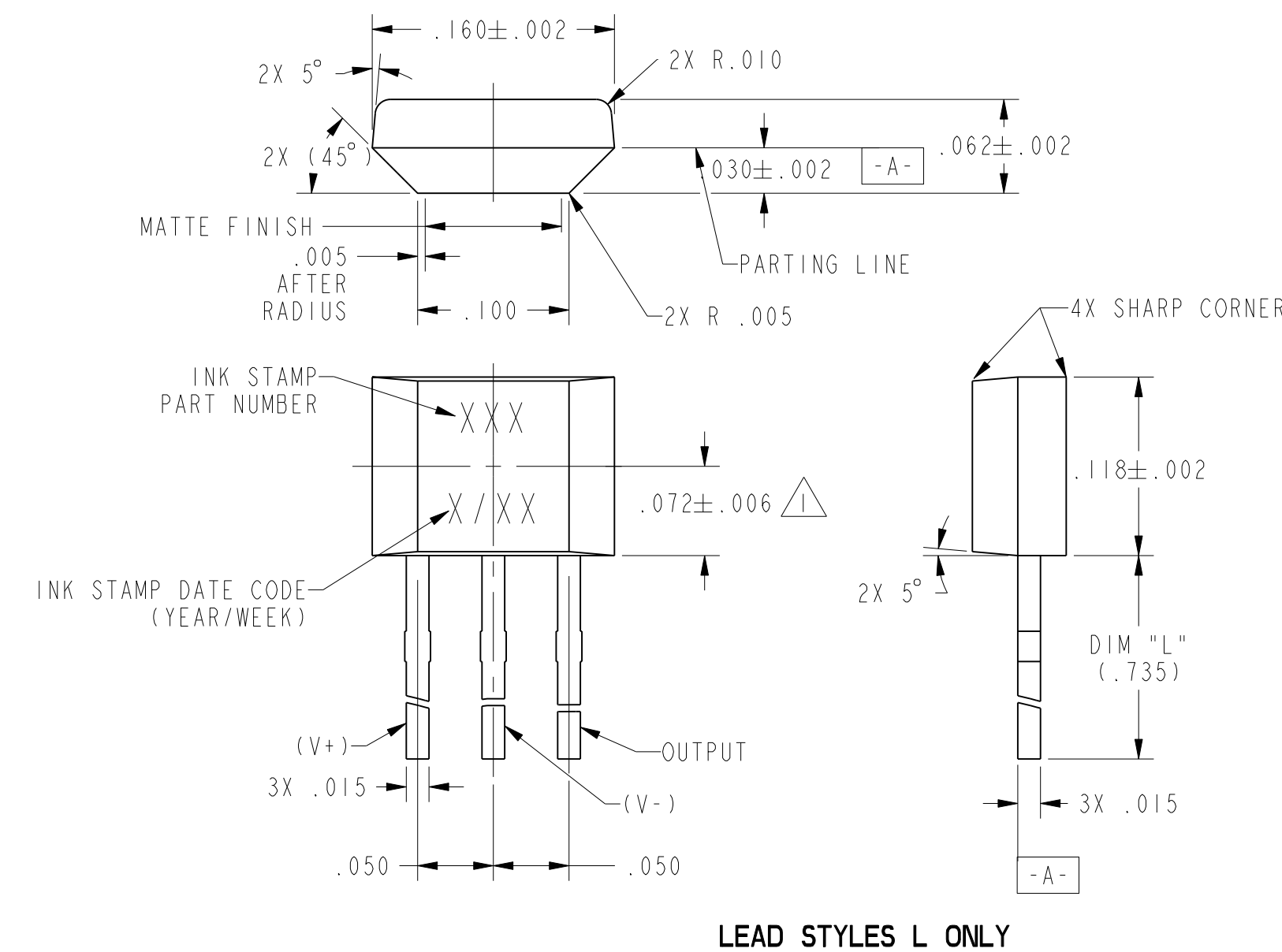
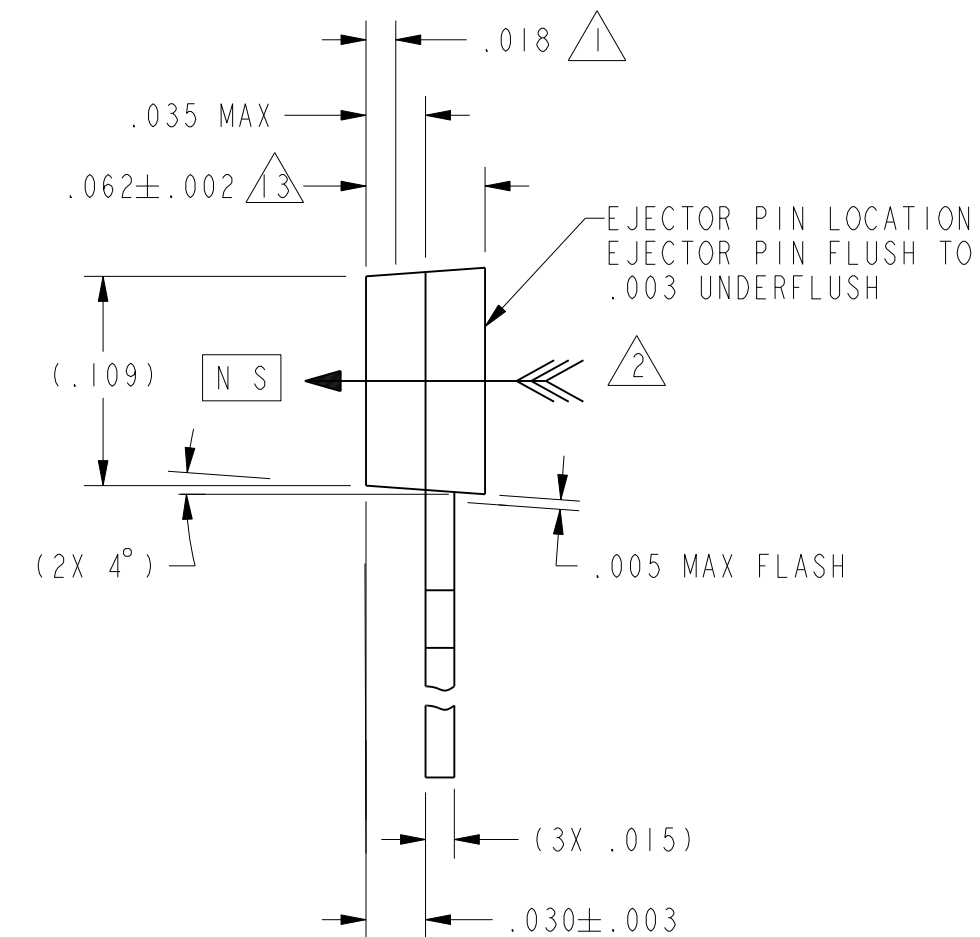

LEAD STYLES L ONLY

MISS49E SERIES CHART 1
 DRAWING NUMBER: 67
 PAGE 1 OF 2
 RELEASE NO. 0000168
 ISSUE: 67
 DATE: 01 AUG 02
 CHECKED: 03197
 DATE: 03 MAR 03
 DESIGNED: 0000166
 DATE: 03 APR 03
 DRAWN: 0000946
 DATE: 21 JUL 03
 CHECKED: 0002137
 DATE: 03 DEC 03
 DESIGNED: 0014910
 DATE: 03 JUN 05
 DRAWN: PTC/CAD 20
 DATE: 13 JUN 02
 CHECKED: SAV
 DATE: 3 JUN 02
 APPROVED: GRT

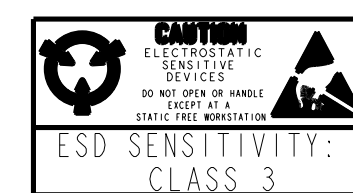

THIS DRAWING COVERS A PROPRIETARY ITEM AND IS THE PROPERTY OF MICRO SWITCH, A DIVISION OF HONEYWELL. THIS DRAWING IS NOT TO BE COPIED OR USED WITHOUT THE APPROVAL OF MICRO SWITCH.

FED. MFG. CODE 91929

MICRO SWITCH
a Honeywell Division

CATALOG LISTING
LINEAR HALL EFFECT SENSOR SS49E SERIES CHART 1

THIRD ANGLE PROJECTION	
SCALE	10 : 1
DO NOT SCALE PRINT	
UNLESS OTHERWISE SPECIFIED TOLERANCES ARE	
ONE PLACE	(.0) +.030
TWO PLACE	(.00) +.015
THREE PLACE	(.000) +.005
ANGLES	+2°
WEIGHT	

CHARACTERISTICS ARE AT $V_s=5.00$ WITH 10K OUTPUT TO MINUS
WITH $T_A=-40^{\circ}\text{C}$ TO $+85^{\circ}\text{C}$ UNLESS OTHERWISE SPECIFIED

PARAMETER	CONDITIONS	MIN	TYP	MAX	UNITS
SENSITIVITY	$T_A = 25^{\circ}\text{C}$	1.0	1.4	1.75	mV/GAUSS
NULL	$T_A = 25^{\circ}\text{C}$	2.25	2.50	2.75	VOLTS
SUPPLY CURRENT			6	10.	mA
OUTPUT CURRENT SOURCE	$V_s > 3.0$	1	1.5		mA
RESPONSE TIME			3		μS
OUTPUT VOLTAGE SWING VOM - VOM +	-B APPLIED	1.05	.95		VOLTS
	+B APPLIED	$V_s - 1.05$	$V_s - .95$		VOLTS
B LIMITS FOR LINEAR OPERATION	-B MAX	-650	-1000		GAUSS
	+B MAX	+650	+1000		GAUSS
V_{null} DRIFT	$B = 0, T_A = -40^{\circ}\text{C}$ TO $+85^{\circ}\text{C}$	-.10		+.10	% / $^{\circ}\text{C}$
SENSITIVITY DRIFT	$T_A = +25^{\circ}\text{C}$ TO $+85^{\circ}\text{C}$	-.15		+.05	% / $^{\circ}\text{C}$
SENSITIVITY DRIFT	$T_A = -40^{\circ}\text{C}$ TO $+25^{\circ}\text{C}$	-.04		+.185	% / $^{\circ}\text{C}$
LINEARITY	$B = -650$ TO $+650$		-.7		% OF SPAN
SUPPLY VOLTAGE	-40°C TO $+100^{\circ}\text{C}$	2.7	5.0	6.5	VOLTS
OPERATING TEMP		-40		+100	$^{\circ}\text{C}$

BLOCK DIAGRAM CURRENT SOURCING OUTPUT

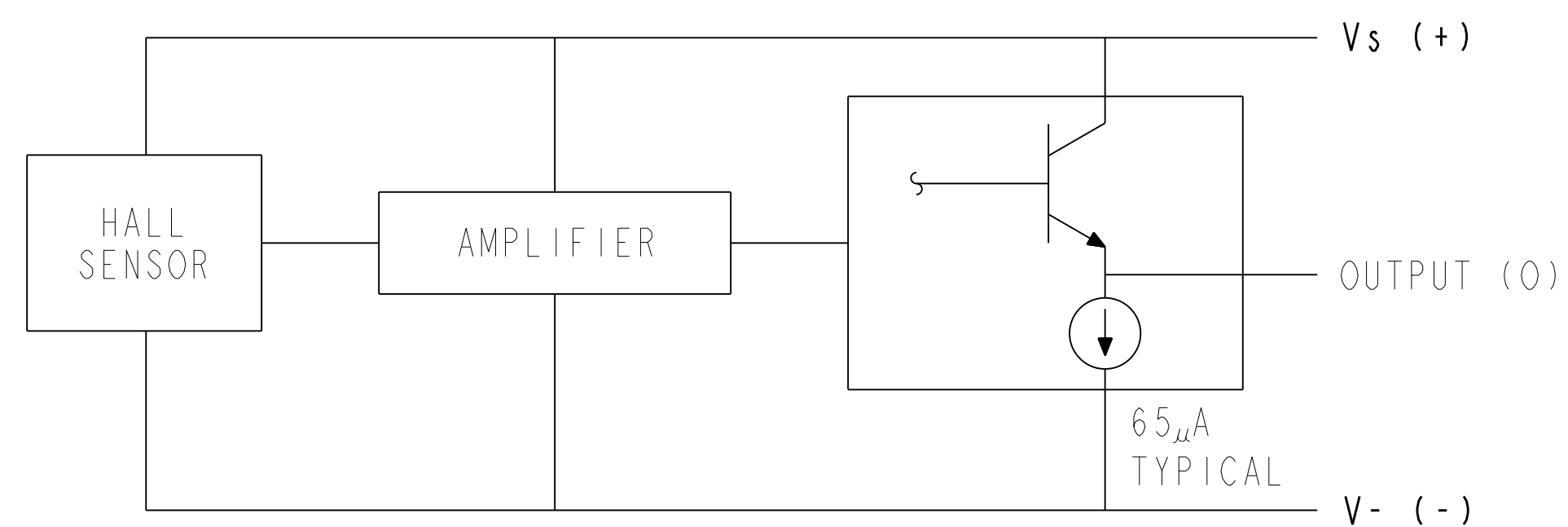

ABSOLUTE MAXIMUM CHARACTERISTICS $\triangle 10$

CHARACTERISTIC	SYMBOL	TEST CONDITION	MIN	MAX	UNITS
SUPPLY VOLTAGE	V_s		-0.5	8	V
OUTPUT VOLTAGE	V_{out}		-0.5	8	V
OUTPUT CURRENT	I_{out}	SOURCE		10	mA
TEMPERATURE	T_A	OPERATING	-40	100	$^{\circ}\text{C}$
	T_s	STORAGE ($V_s=0$)	-55	165	$^{\circ}\text{C}$

NULL SHIFT VERSUS TEMPERATURE

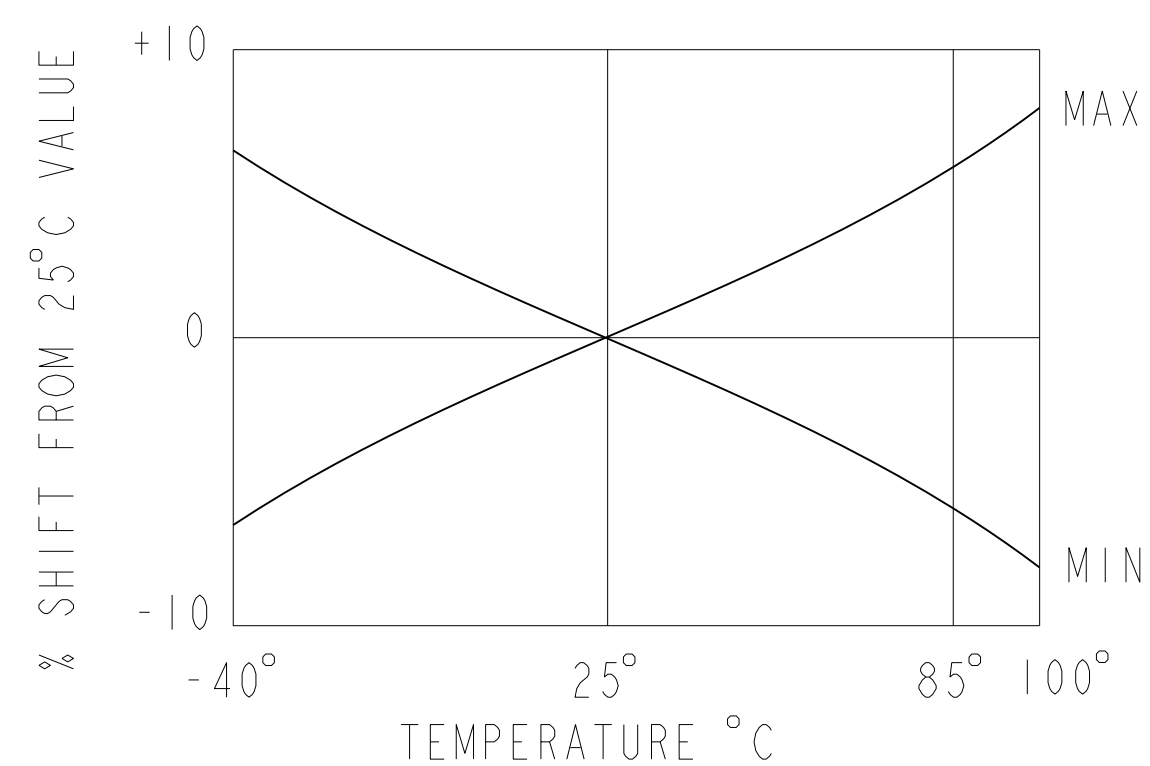

RATIO OF V_{null} TO V_s

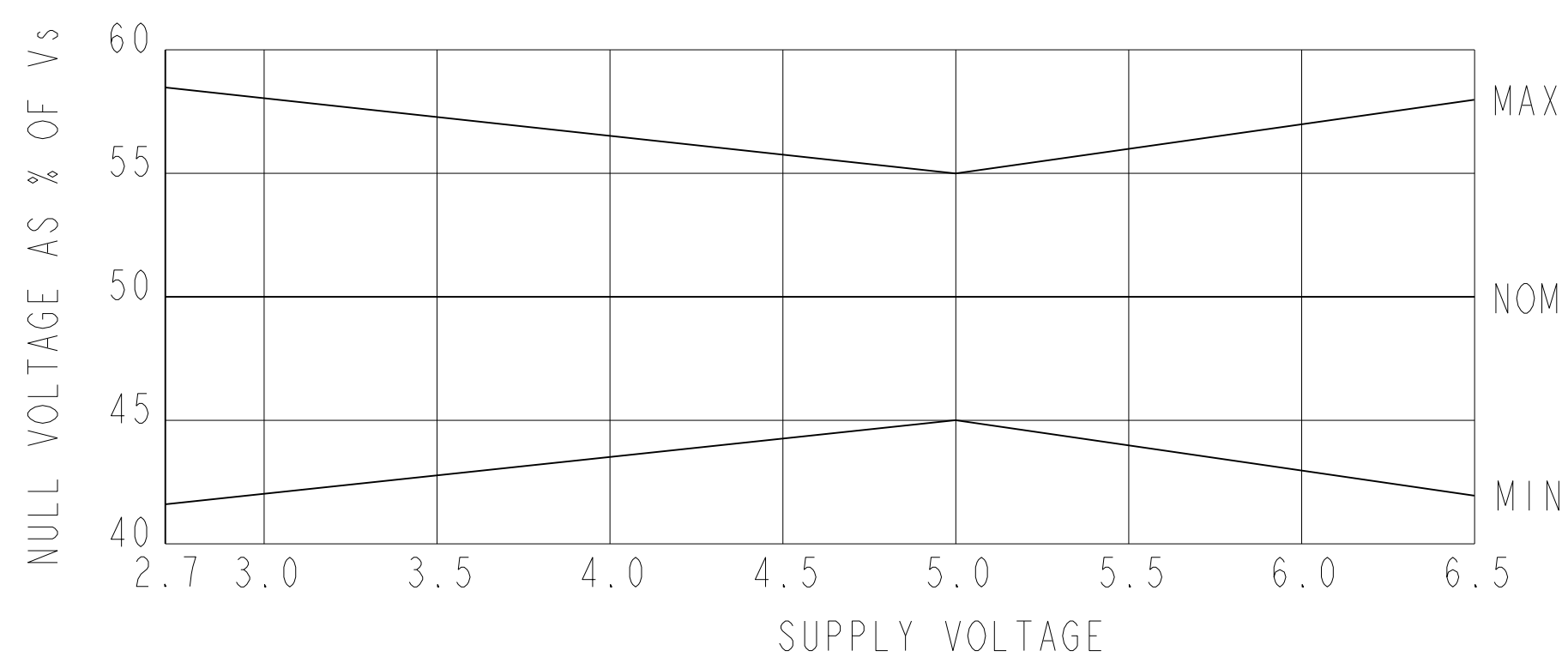

SENSITIVITY/V VERSUS V_s
(mV/Gauss/Volt)

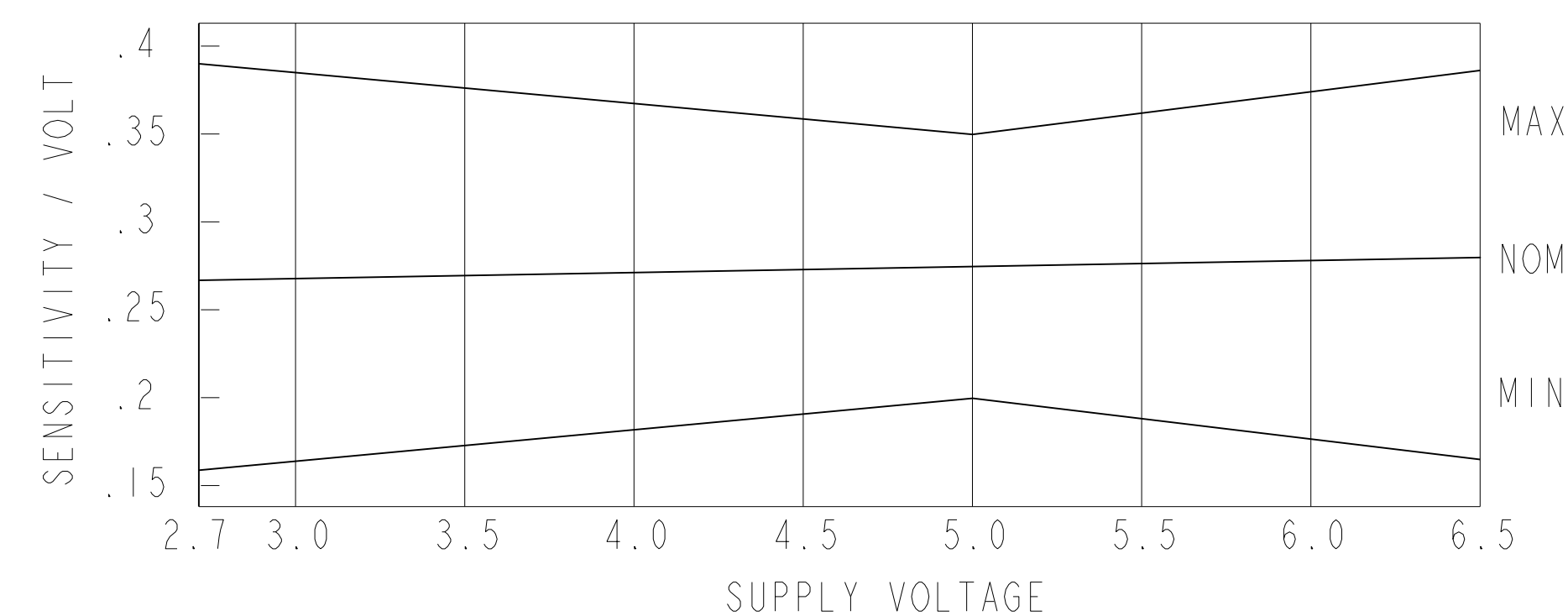

TRANSFER CHARACTERISTICS
AT $V_s=5.0$ VDC

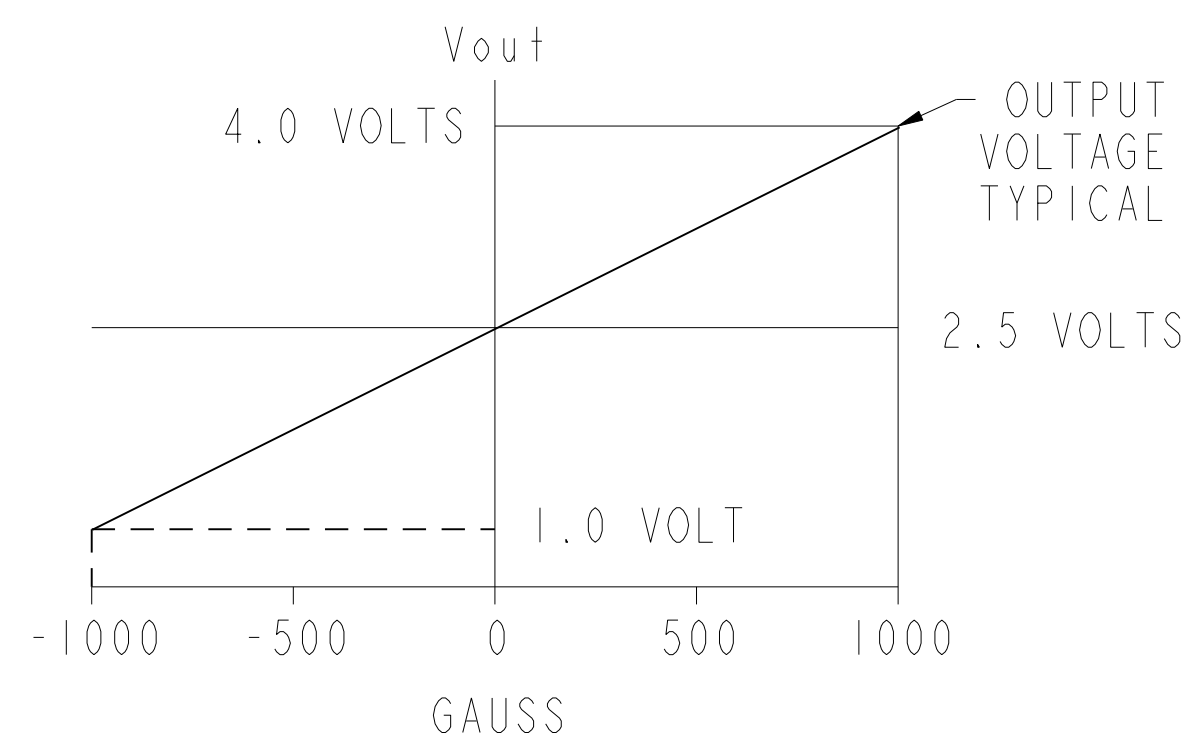

SUPPLY CURRENT
VERSUS TEMPERATURE

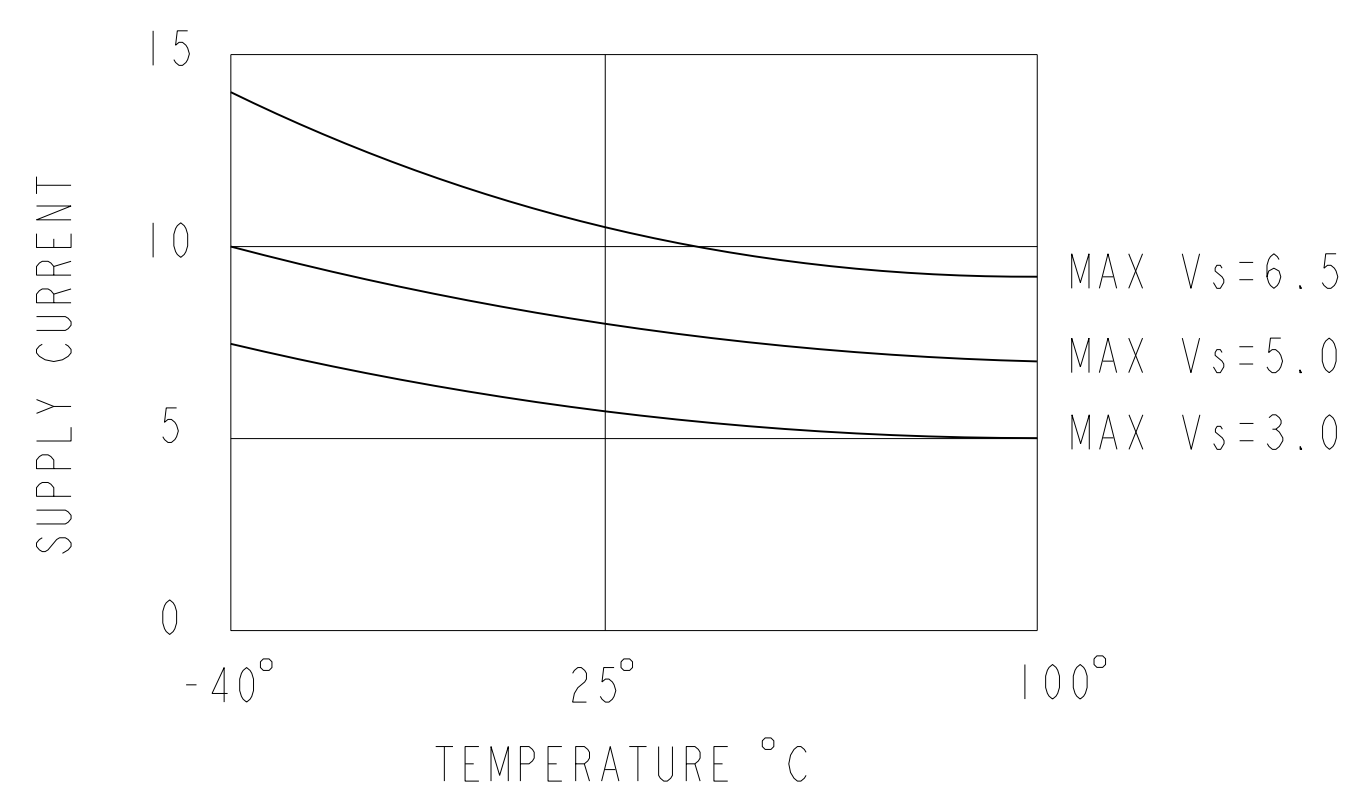

TYPICAL FREQUENCY RESPONSE

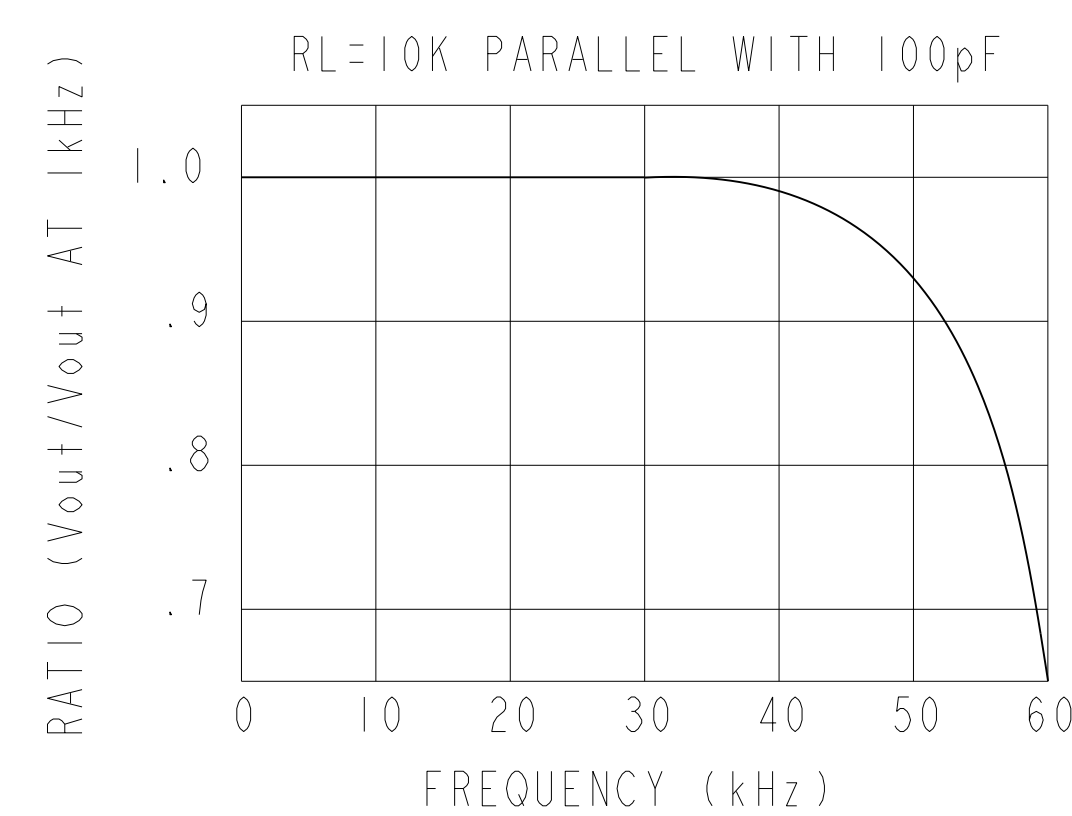

SENSITIVITY
SHIFT VERSUS TEMPERATURE

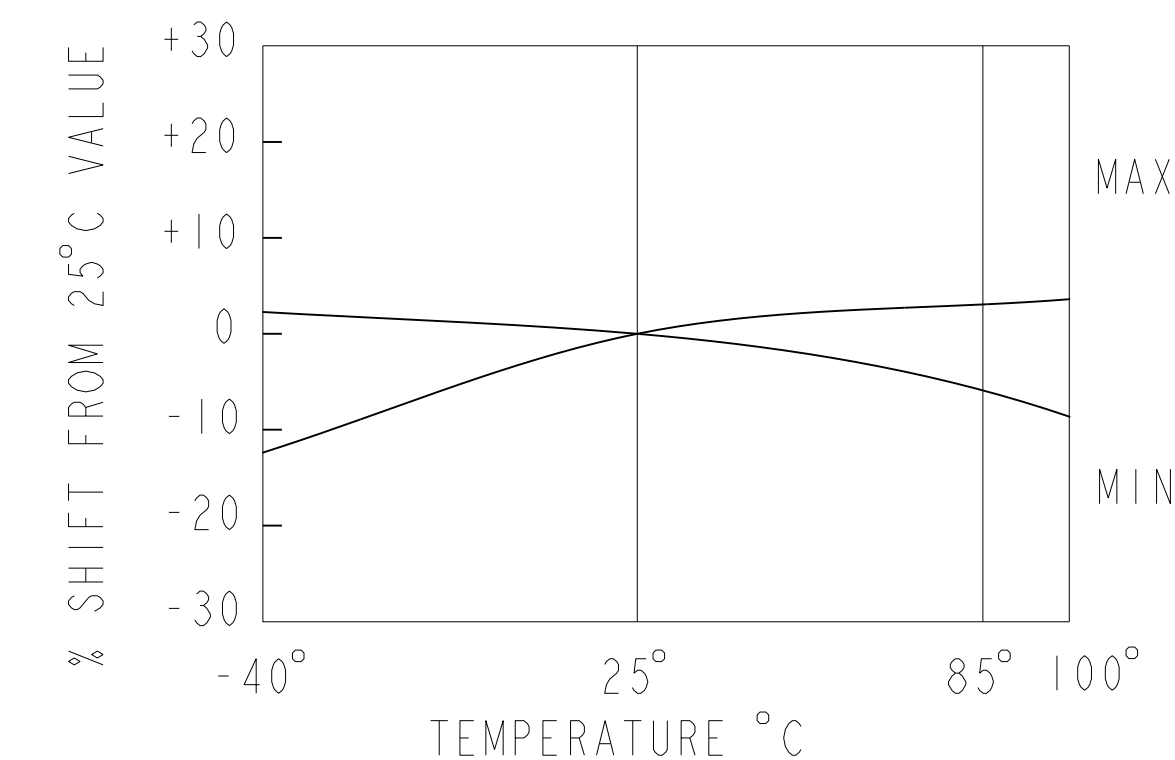

ISSUE 67
 DRAWING NUMBER 24APR03
 RELEASE NO. 0000168
 REVISIONS
 1 0000168
 2 24APR03
 3 0000168
 4 0000168
 5 0000168
 6 0000168
 7 0000168
 8 0000168
 9 0000168
 10 0000168
 11 0000168
 12 0000168
 13 0000168
 14 0000168
 15 0000168
 16 0000168
 17 0000168
 18 0000168
 19 0000168
 20 0000168
 21 0000168
 22 0000168
 23 0000168
 24 0000168
 25 0000168
 26 0000168
 27 0000168
 28 0000168
 29 0000168
 30 0000168
 31 0000168
 32 0000168
 33 0000168
 34 0000168
 35 0000168
 36 0000168
 37 0000168
 38 0000168
 39 0000168
 40 0000168
 41 0000168
 42 0000168
 43 0000168
 44 0000168
 45 0000168
 46 0000168
 47 0000168
 48 0000168
 49 0000168
 50 0000168
 51 0000168
 52 0000168
 53 0000168
 54 0000168
 55 0000168
 56 0000168
 57 0000168
 58 0000168
 59 0000168
 60 0000168
 61 0000168
 62 0000168
 63 0000168
 64 0000168
 65 0000168
 66 0000168
 67 0000168
 68 0000168
 69 0000168
 70 0000168
 71 0000168
 72 0000168
 73 0000168
 74 0000168
 75 0000168
 76 0000168
 77 0000168
 78 0000168
 79 0000168
 80 0000168
 81 0000168
 82 0000168
 83 0000168
 84 0000168
 85 0000168
 86 0000168
 87 0000168
 88 0000168
 89 0000168
 90 0000168
 91 0000168
 92 0000168
 93 0000168
 94 0000168
 95 0000168
 96 0000168
 97 0000168
 98 0000168
 99 0000168
 100 0000168

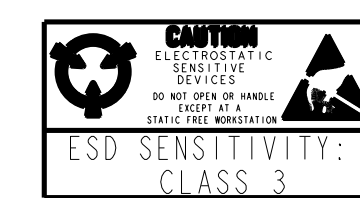

THIS DRAWING COVERS A PROPRIETARY ITEM AND IS THE PROPERTY OF MICRO SWITCH, A DIVISION OF HONEYWELL. THIS DRAWING IS NOT TO BE COPIED OR USED WITHOUT THE APPROVAL OF MICRO SWITCH.

FED. MFG. CODE 91929

MICROSWITCH
a Honeywell Division

LINEAR HALL EFFECT SENSOR

SS49E SERIES CHART 1

ONE PLACE (.0) +.030
TWO PLACE (.00) +.015
THREE PLACE (.000) +.005
ANGLES +
WEIGHT

THIRD ANGLE PROJECTION

SCALE NONE

DO NOT SCALE PRINT

UNLESS OTHERWISE SPECIFIED TOLERANCES ARE